

RELIEF VALVES

SPECIFICATIONS

Fluid viscosity:	ISO 3448
Filtration:	ISO 4406
Fluid temperature:	-20°C + 90°C
Ambient temperature:	-20°C + 50°C
Max. operating pressure:	350 Bar
Standard seals:	NBR
Manifold material:	Zinc plated steel

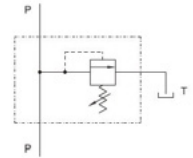

DIMENSIONS (mm)

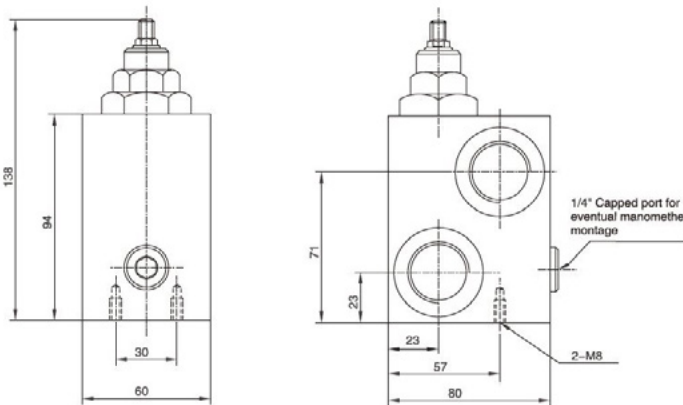

PERFORMANCE

Oil viscosity 24 mm³/s (3,5 °E) - Temperature 50°C

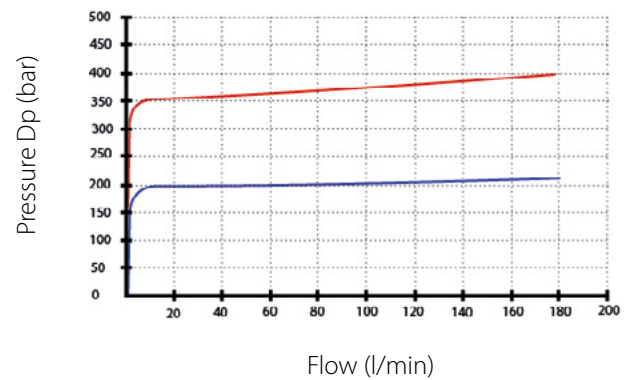

Std setting at 5 l/min

30 = 10 - 50 bar	30 bar
25 = 20 - 100 bar	70 bar
18 = 10 - 180 bar (Std)	90 bar
10 = 50 - 250 bar	130 bar
5 = 80 - 300 bar	150 bar

Standard code	Thread	M	L	L1	L2	L3	L4	L5	L6	G	H	S	Weight (kg)	Q max (l/min)
K-DRLV-180	1"	1/4	77	139	17.5	29.5	54	8.5	30	6.5	45	45	1.0	70